

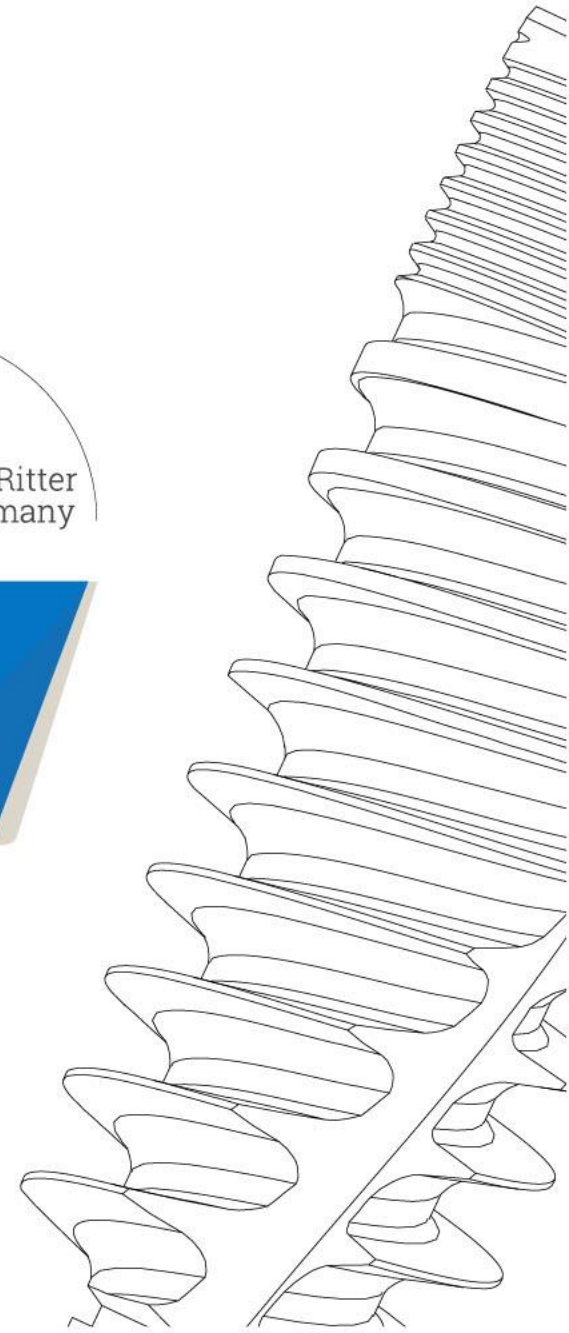

 Ritter
Made in Germany

33 Reasons for Ritter Implants

Quality. Aesthetics. Precisions.



Reason #1



Ritter Implants are made of the strongest “**Grade 5**” **Titanium** alloy which goes through a special **sandblasting and etching process**.

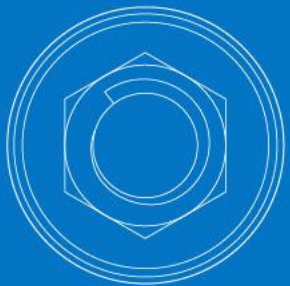

Reason #2



**All Ritter Implants include a
Cover Screw.**

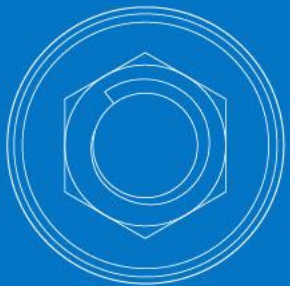

Reason #3



All Ritter Abutments are packaged including an **Abutment Fixation Screw** made of **Titanium Grade 5**.

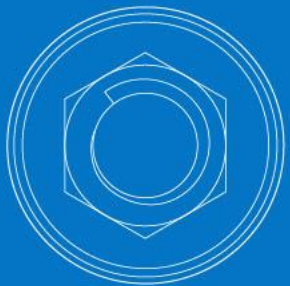

Reason #4



The overall **superior Implant design** attributes to the Ritter Implants Increased primary stability and High Insertion torque values.

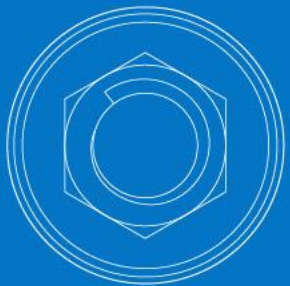

Reason #5

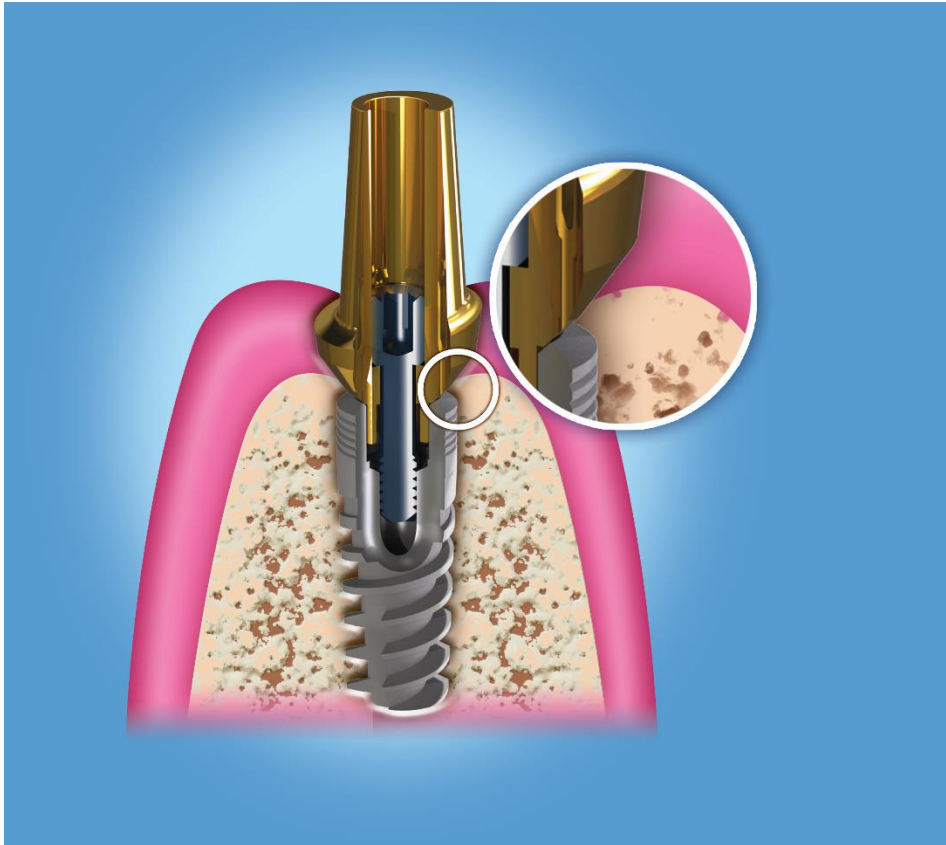

The internal **Hex Connection** (Platform) is the most widely used connection in the industry.

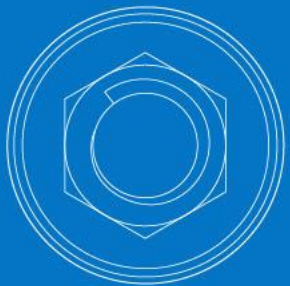

Reason #6

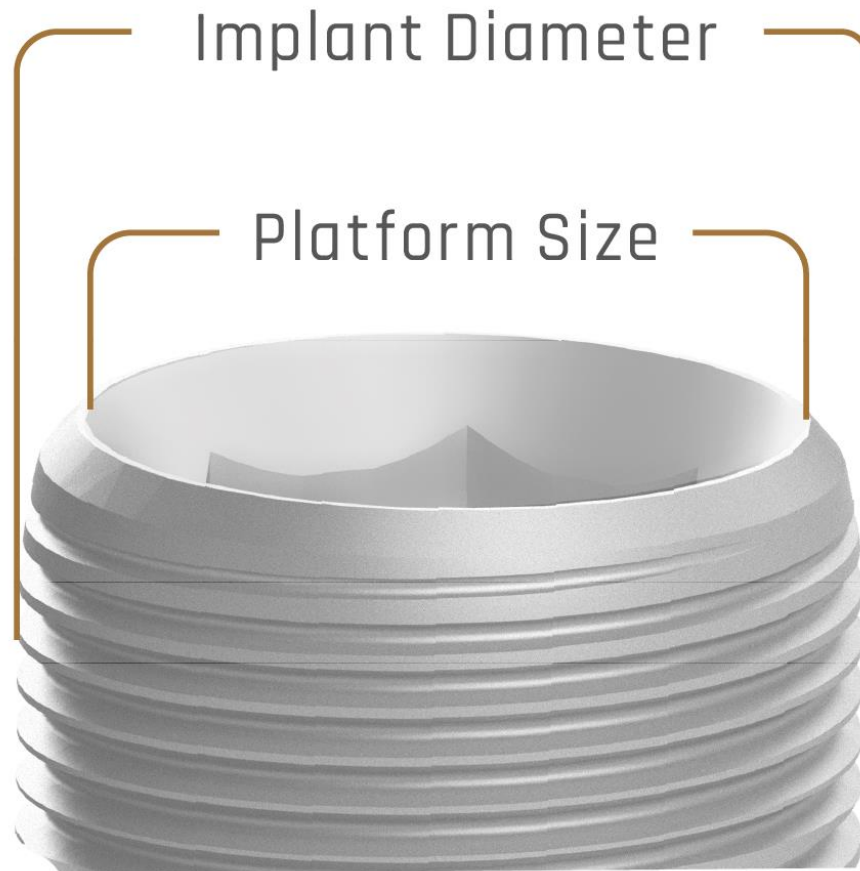

Ritter Implants has **two platforms** and a wide range of **Platform Shifting/Switching.**

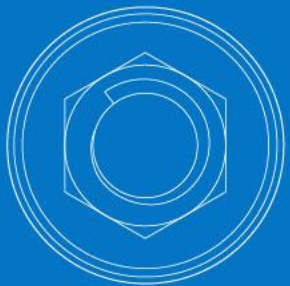

Reason #7



6 mm **short Implants**
in the 5 and 6 mm Diameters.

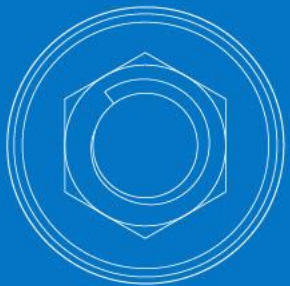

Reason #8



Ritter Implants provides a **Narrow Line** with diameters of 3.0/3.3 mm

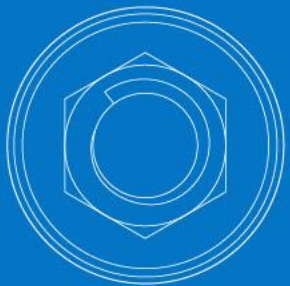

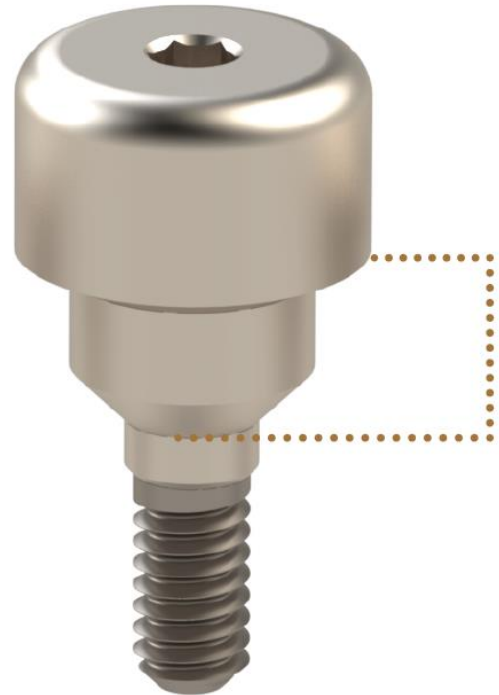

Ritter
Emergence
Profile

Ritter Implants Abutments provide an **Emergence Profile** for perfect soft tissue management.



Reason #10



Ritter Implants is the only company who provides an **Angled Closed Tray Impression Coping, 15°/25°**.

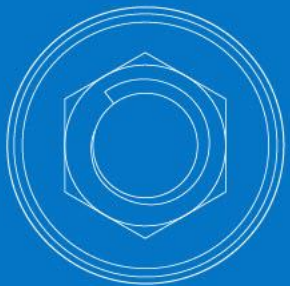

Reason #11



Ritter Implants **Scan Body/Abutment** is a **dual purpose scan body and temporary/provisional abutment.**

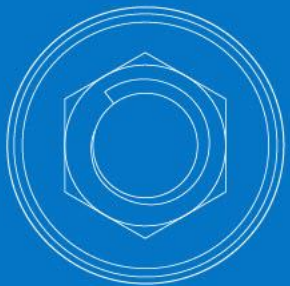

Reason #12

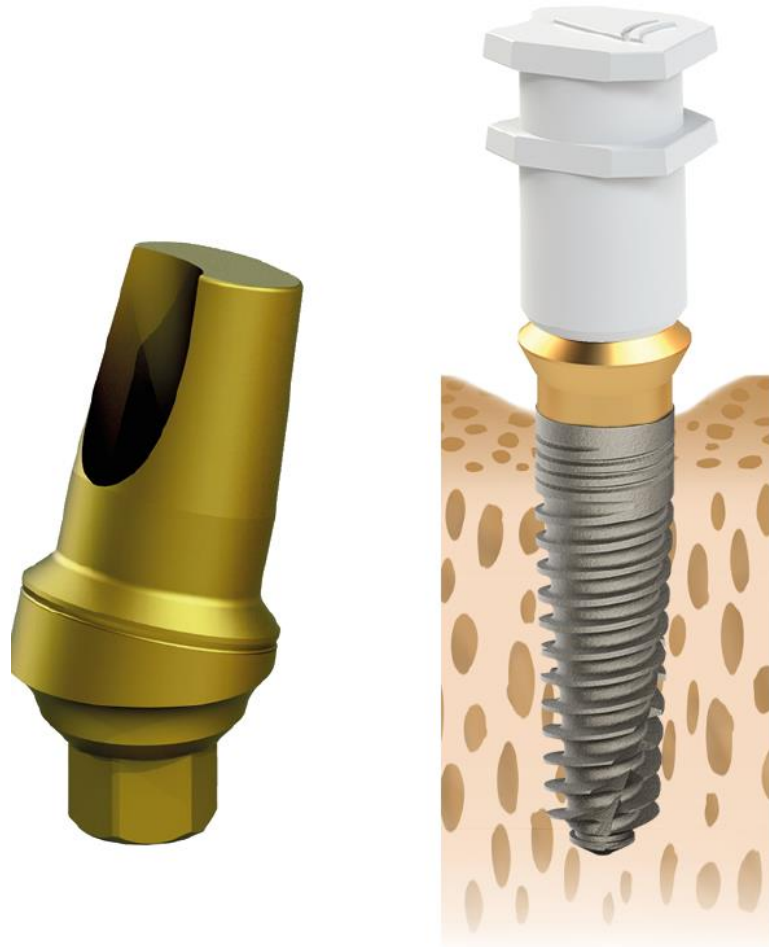

Ritter Implants Pick Up transfer abutments “**PUT**” can not only be used for taking an **impression** but **also for the final prosthesis made from Titanium Grade 5**. Our “**PUT**” also come in Angled 15°/25°, exclusively by Ritter Implants.

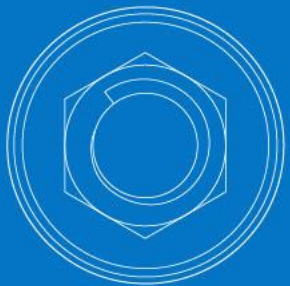

Reason #13



All Ritter abutment screws are customized to accept the **same screw driver - no matter what platform** or type of abutment.

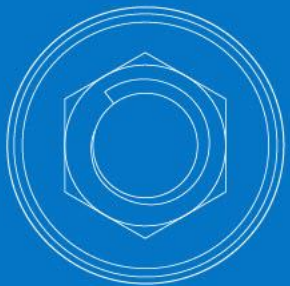

Reason #14

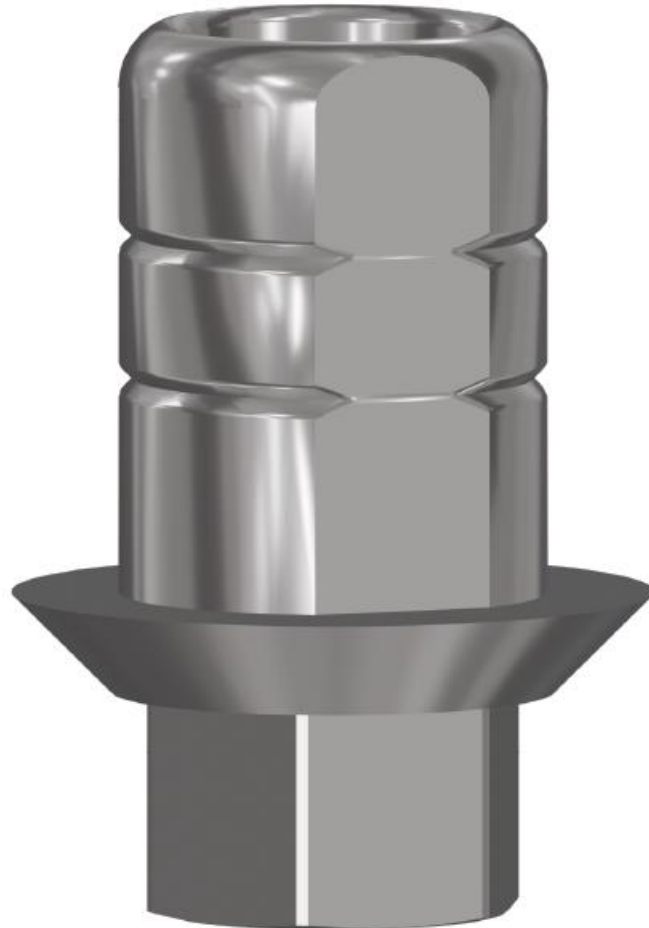

Ritter's AZA line are made in both Chromium Cobalt and Titanium and are dual purpose as they can be used as **Castable with Chromium Cobalt** or a **Tibase made from Titanium**.

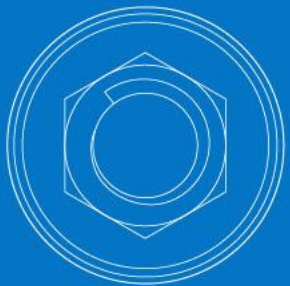

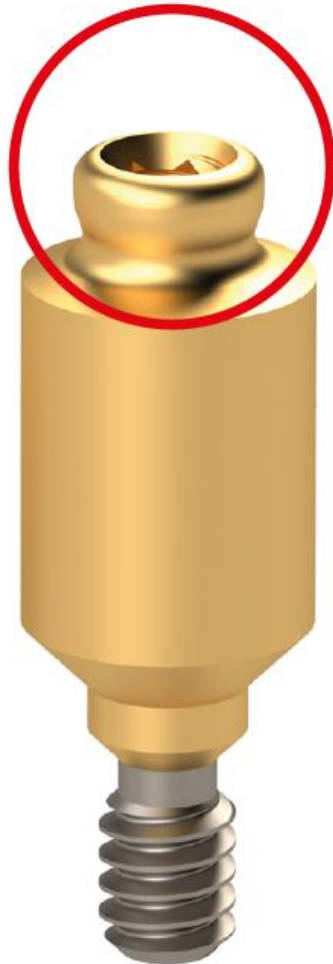

Clicq™ Overdenture is known around the world as an “Equator,” offering **a narrower profile** than traditional overdenture abutments.***



Reason #16

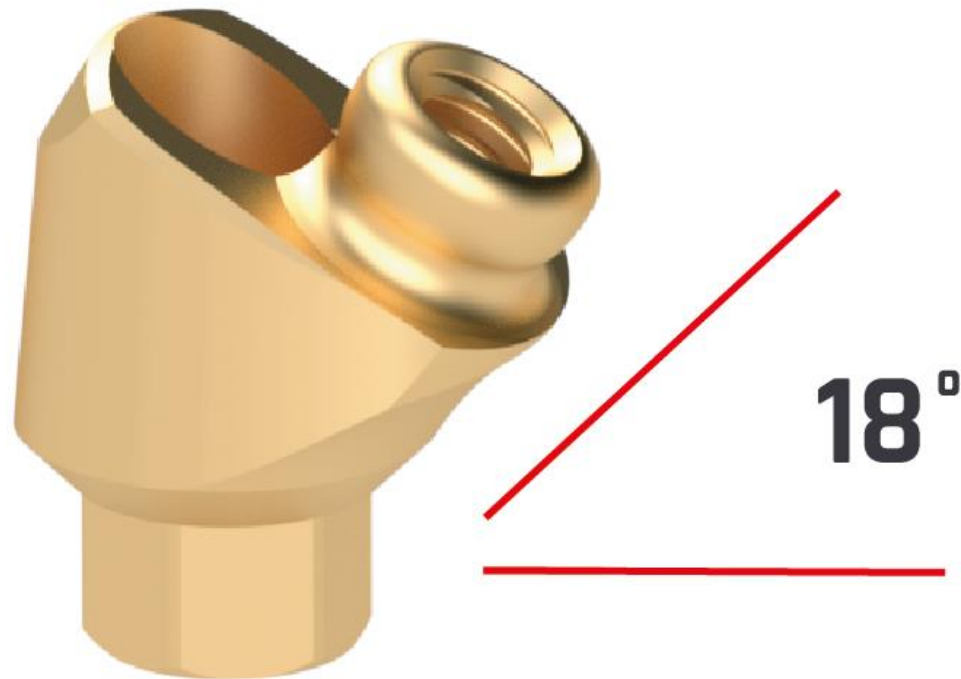

Clicq™ Overdenture is manufactured in **angled versions encompassing 18° and 30°**. ***

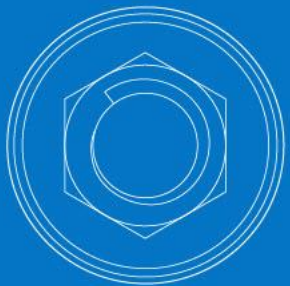

Reason #17



Clicq™ Overdenture PLUS offers a more traditional wide profile ***

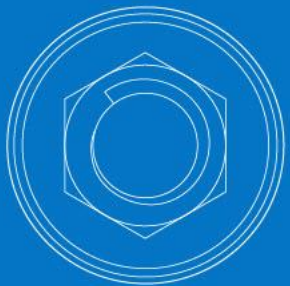

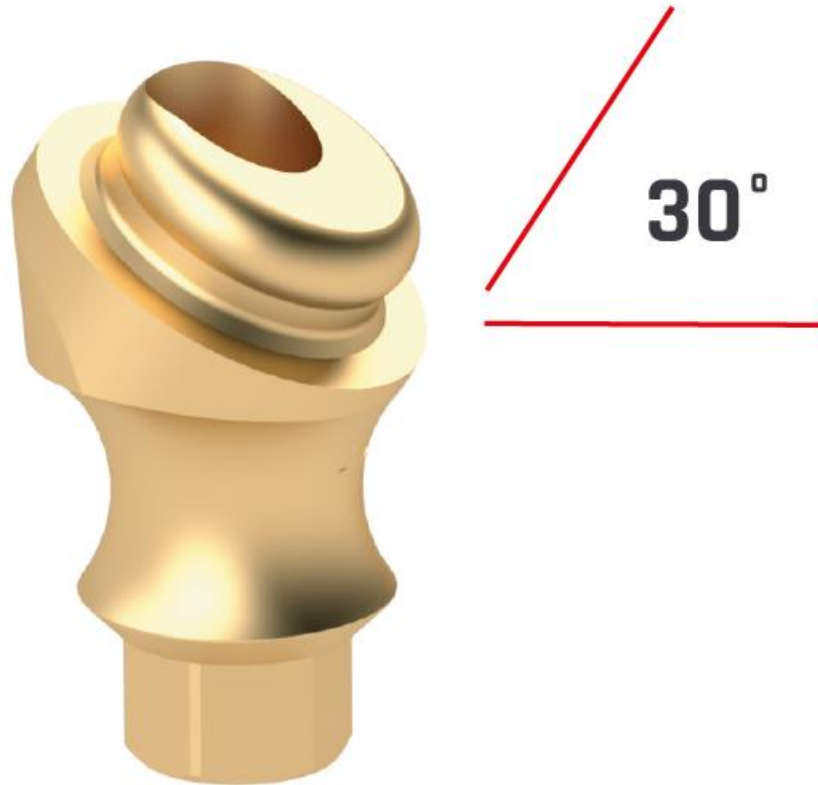

The Clicq™ overdenture Plus is manufactured in angled versions encompassing 18° and 30°. ***

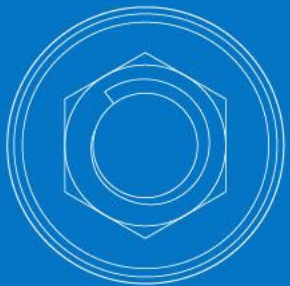

Reason #19



Ritter Multi Abutments have been manufactured with a wider stronger M1.6 screw instead of a M1.4 screw that most companies use on Multi unit restorations. **Ritter offers this packaged with very commonly used accessories.**

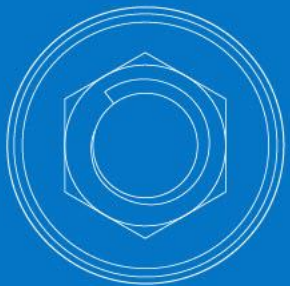



Ritter Multi Abutments
are also made for its
3.0 and 3.3 Narrow line platform.

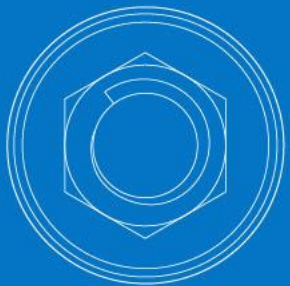

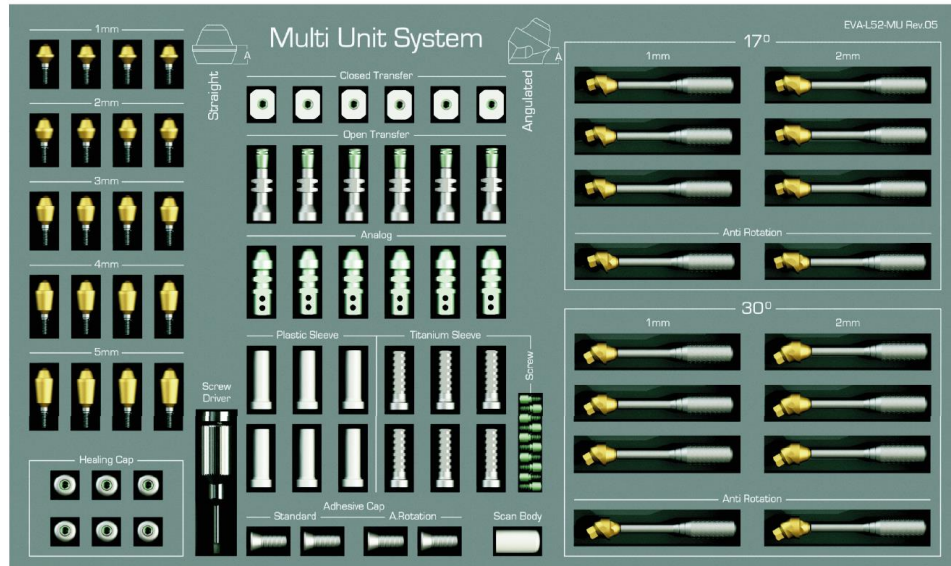

Multi Unit Kits:
**Special Kit Comes
with 36 Abutments**
making a complicated
procedure much easier!

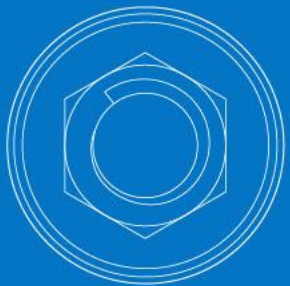

Reason #22



Ritter Implants were the first to **transition a patient from a removable Denture** to an “all on X” as a removable case can be planned with the “Angled Clicq™” abutments.

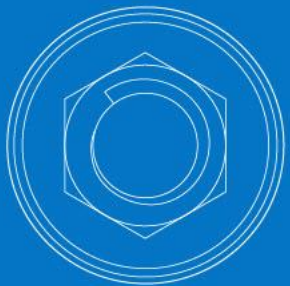



All Surgical Kits contain all basic tools to place **all Ritter Platforms**.



Reason #24



The Compact Surgical Kit contain all basic tools and drill stop function provided by drill **stopper sleeves** with the tools to place **all Ritter Platforms**.

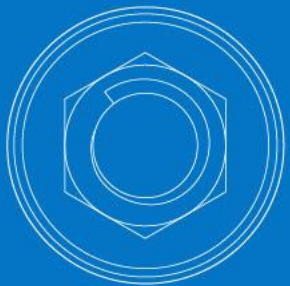



All Ritter Implants Surgical Kits are equipped with a complete prosthetic selection of the Ratchet, Handpiece, Hand Torque Drivers – **purchase of a separate Prosthetics Kit is unnecessary with Ritter Implants.**

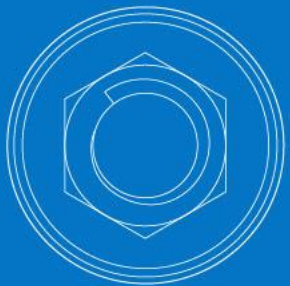

Reason #26

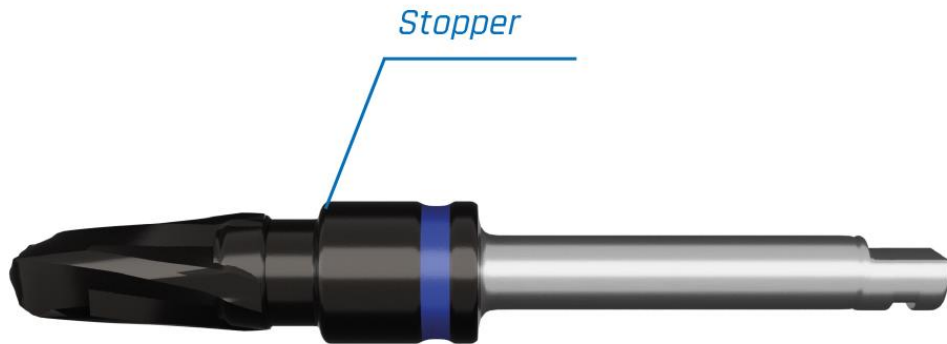

Our Complete Surgical Kit is the easiest and safest Surgical Kit – containing all the items of the Compact kit- except the **Stoppers are built into each drill** – there is a drill for every Implant we produce and more!

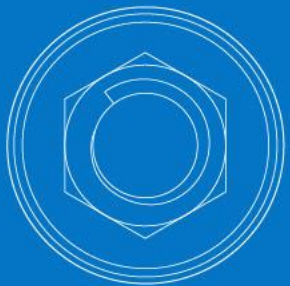

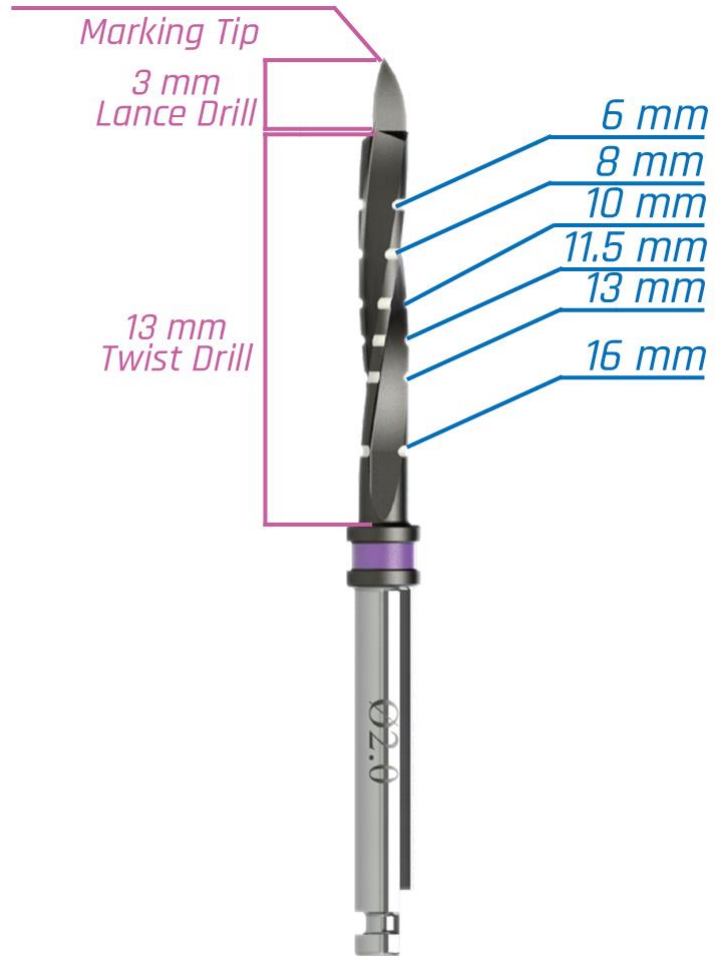

Our Complete Surgical Kit is equipped with our exclusive **3 in 1 Starter/Marking/Lance Drill.**

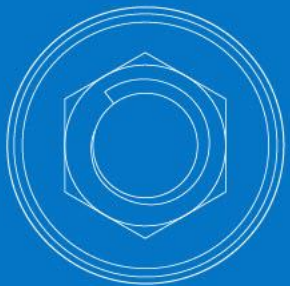

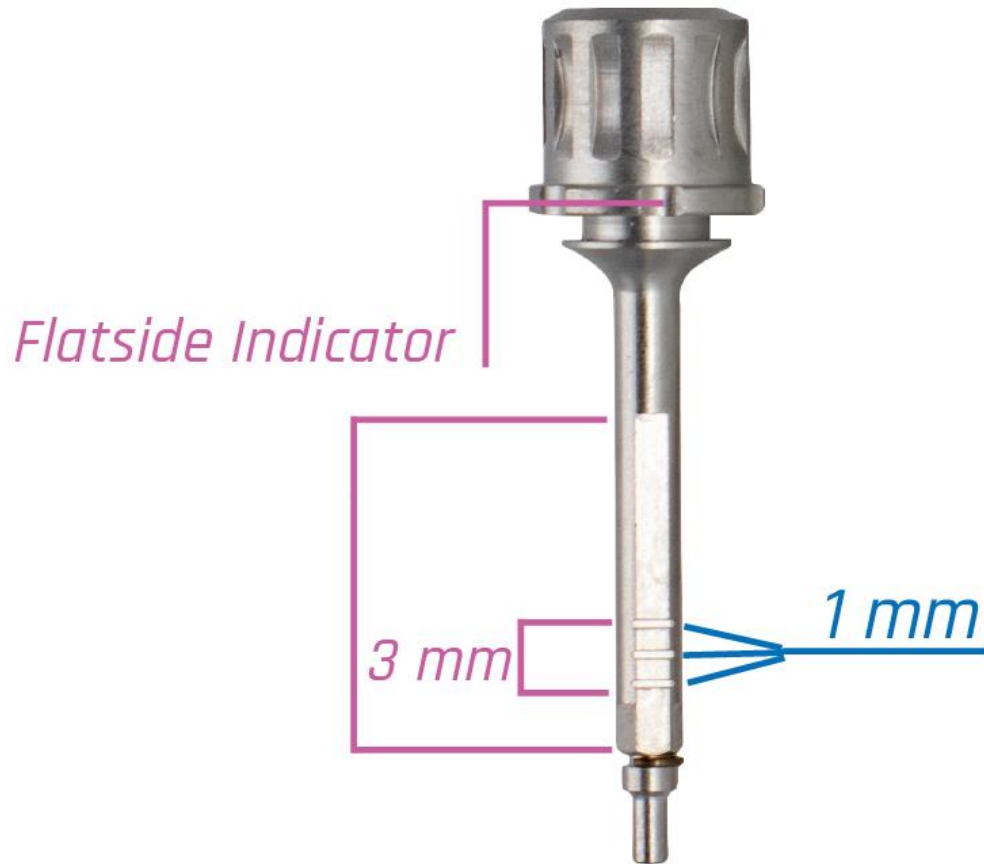

Our Complete Surgical Kit provides implant placing drivers with **special measuring and registration markings on all tools.**

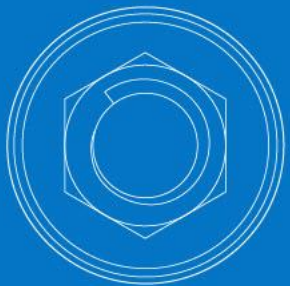

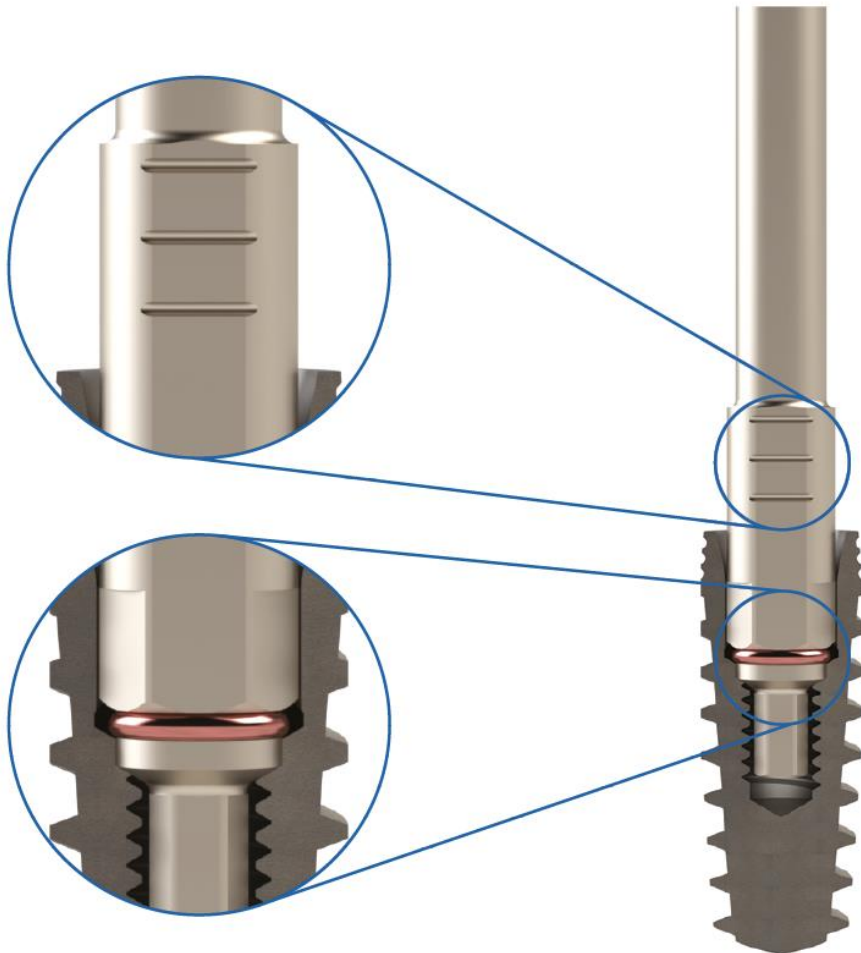

All Implant Drivers are spring loaded – making it Impossible for an Implant to be dislodged.

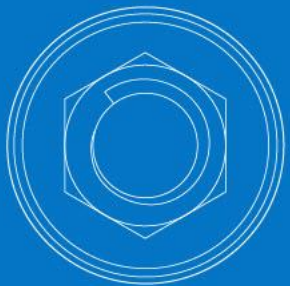

The **Guided Kit** is one of the Best and Easiest on the Market containing **a drill for every length and diameter.**

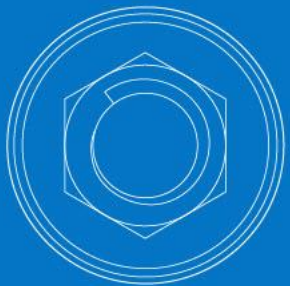

Reason #31

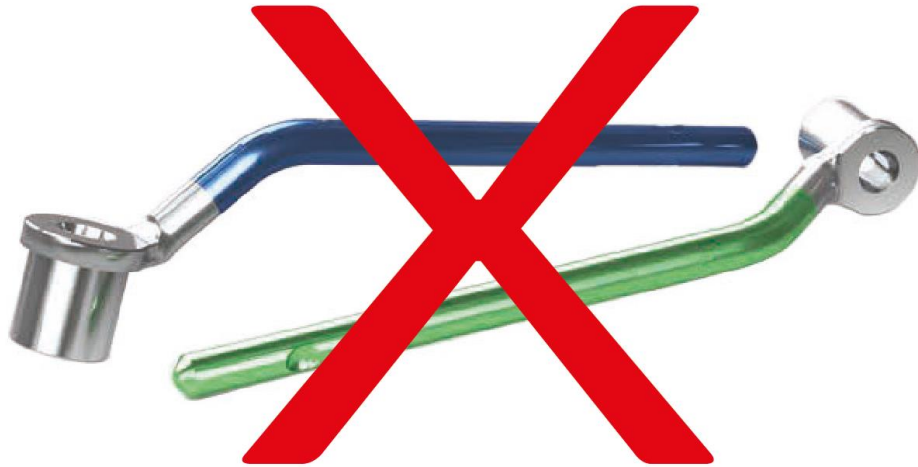

Most guided kits need to use spoons to change drill diameter –
Ritter is spoonless!

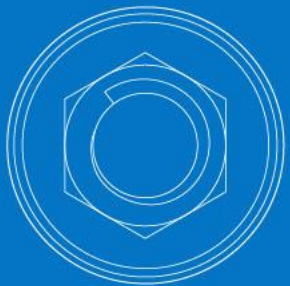

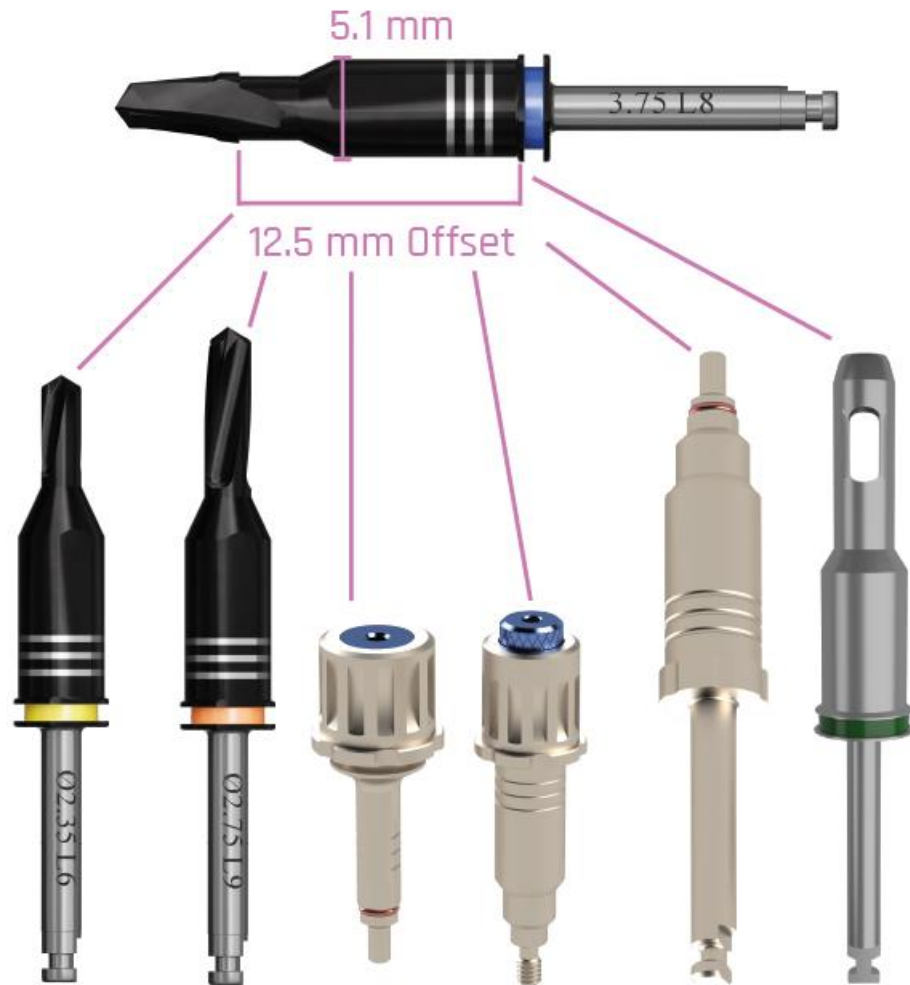

Most guided kits need metal sleeves in the guide because they guide the cutting portion of the drill – **Ritter guides the barrel of the drill – and is sleeveless!**

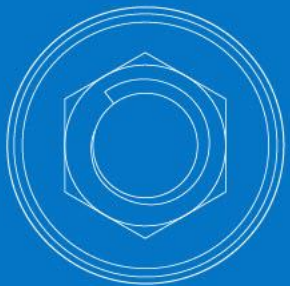

Reason #33



The **Torque Ratchet** has a simple Screw to **reverse the direction of turning.**

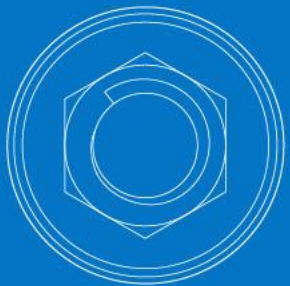

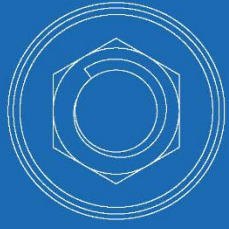

Thank you



Ritter Implants GmbH & Co. KG

Freiburger Str. 45
88400 Biberach an der Riß, Germany
Fon +49 7351 / 52 925-10
Fax +49 7351 / 52 925-21

www.ritterimplants.com

